

**ACHIEVER**  
TC-55 TRACKED AERIAL

**ML** MOBILE LIFTS, LLC  
Sales • Service • Rentals • Accessories

# *The Ultimate 58 ft Working Height, Low Ground Pressure Tracked Aerial*

Level off to within 5° on 12° slopes  
Haul on a 15 Ton Trailer



UTV Achiever Carrier with a Terex Optima TC-55 High Ranger





DIMENSIONS / WEIGHT	
Overall Length	360"
Overall Width	101"
Overall Height	118"
Ground Clearance	16"
Weight & Payload	
- Basic Vehicle	20,600 lbs (Basic vehicle with boom)
- GVW	24,000 lbs
Deck Area	87" x 87" (approximately)

PERFORMANCE DATA	
Maximum speed	8 mph (loaded)
Inside turning radius	0 ft.
Climbing Ability	
- Uphill	40° (84%)
- Side-hill	15° (27%)
Ground Pressure	2.83 PSI with boom, typical, 3.44 PSI max load
Normal Driving Range	12 Hours (40 U.S. gallon fuel tank)

ENGINE	
Make	Deutz AG
Model	TCD 3.6 L4, 4 cylinder Turbo Charged Diesel
Horsepower	134 HP @ 2,300 RPM
Displacement	3.6 liters
DEF Tank	2.6 gals.
Fuel capacity	40 gals.
Torque	369 ft lbs. @ 1,600 RPM

FRAME / SUSPENSION	
Type	Corten Welded Tub
Axles	Independent Torsion Axles
Tires	Solid Rubber

**Suspension system comes with:**

- 2 independent idler wheels with oil hubs & steel face seals
- 8 x 20" solid wheels with grease hubs & dust cap retainers
- 2 x rear drive sprockets

TRACKS	
Rubber 5 ply belts with 29" rubberized aluminum crosslinks	

STEERING	
Independent dual joysticks with cable control for each track	

ELECTRICAL	
Voltage	12 V
Batteries	2 x 1060 CCA
Alternator Capacity	120 Amps

OPTIONAL EQUIPMENT & ACCESSORIES	
<ul style="list-style-type: none"> <li>• 2 Way front plow</li> <li>• 16,500 lb electric winch</li> <li>• 18,000 lb hydraulic winch</li> <li>• F.O.P.S. Certified Cab</li> <li>• Closed cab</li> <li>• Air Conditioning</li> <li>• Cold weather package</li> <li>• Extreme cold weather package</li> </ul>	<ul style="list-style-type: none"> <li>• Ice claws for tracks</li> <li>• Ice cleats for outriggers</li> <li>• Front brush guard</li> <li>• Side brush guard</li> <li>• Rear view camera</li> <li>• Additional LED lights</li> <li>• Spark arrestor</li> <li>• Pintle hook</li> <li>• 100 Hours service kit</li> </ul>

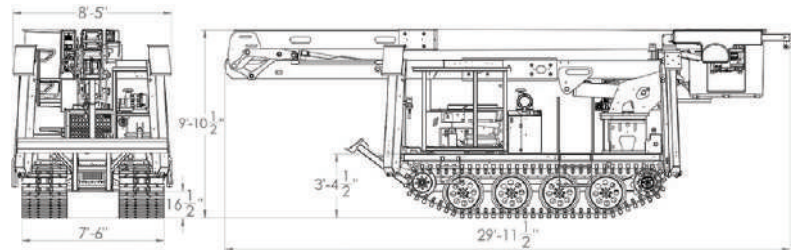

POWERTRAIN FOR HYDROSTATIC DRIVE	
Transmission	Hydrostatic, 2-speed
Parking Brakes	Multi-disc, spring applied & pressure released
Service Brakes	Positive deceleration via hydrostatic transmission

CARRIER STANDARD FEATURES	
<ul style="list-style-type: none"> <li>• 1 Man cab 24,000 lbs R.O.P.S. certified (SAE J1040)</li> <li>• Vinyl seat with mechanical adjustment</li> <li>• 2 Front lights, 1 Rear light and 1 Strobe</li> <li>• Electronic engine protection system</li> <li>• Primary fuel filter with water separator</li> <li>• Operations, Service and Parts Manual</li> <li>• 18" x 20" front outrigger feet</li> <li>• 10" x 10" rear outrigger feet</li> <li>• 2 point seat belt</li> <li>• Open or closed cab</li> <li>• Levels on a 12° slope</li> </ul>	<ul style="list-style-type: none"> <li>• Full instrumentation</li> <li>• Fire extinguisher</li> <li>• Backup alarm</li> <li>• Horn</li> <li>• Extra long 71" heavy duty front hydraulic radial outriggers</li> <li>• Extra long 71" super duty rear hydraulic radial outriggers</li> <li>• Tools outlet at the bucket and/or on deck</li> <li>• Haul on a 15 ton trailer</li> </ul>

AERIAL SPECIFICATIONS	
Dimensions / Capacities	
Working Height	58'
Bottom of Basket	52' 8"
Side Reach	40'
Upper Boom Articulation	+70° to -90°
Lower Boom Articulation	116°
Stowed Travel Height	111"
Basket	24" x 48" x 42"
Material handling jib	2,000 lb

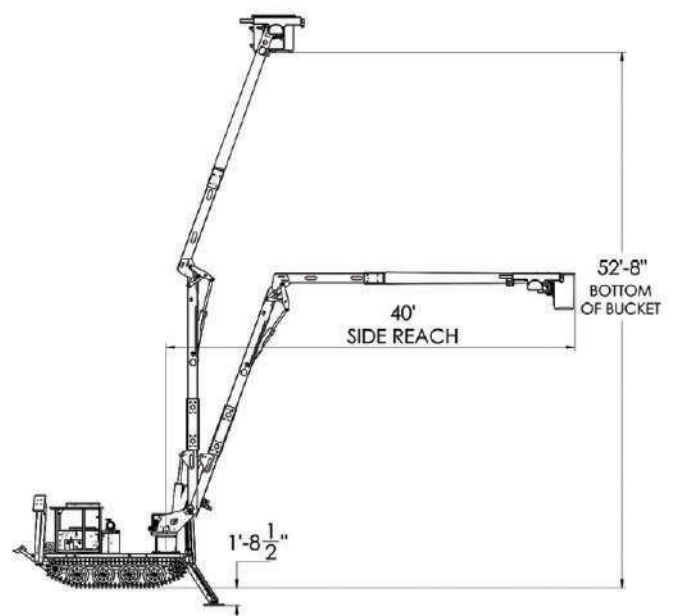

\* Specifications subject to change without notice.