

DPM2 SERIES

Models: DPM2-52, DPM2-47, DPM2-40, DPM2-36, DPM2-32

DUR-A-LIFT®



DPM2-52DU PICTURED

SPECIFICATIONS

	DPM2-52	DPM2-47	DPM2-40	DPM2-36	DPM2-32**
WORKING HEIGHT*	59'	54'	47'	43'	39'
SIDE REACH	31'6"	31'6"	31'6"	27'6"	25'4"
APPROX. STOWED TRAVEL HEIGHT	11'8"	10'5"	10'6"	10'6"	10'8"
HEIGHT TO BOTTOM OF PLATFORM*	54'	49'	42'	38'	34'
BASKET CAPACITY (MH, DU)	400#	400#	400#	400#	400#
BASKET CAPACITY NOT USING JIB (DU)	550#	550#	550#	550#	550#
BASKET CAPACITY (DP)	600#	600#	600#	600#	600#
APPROX. LIFT WEIGHT	4400#	4300#	3900#	3700#	3300#
ARTICULATING ARM TRAVEL	0° to 75°	0° to 75°	0° to 75°	0° to 75°	-
MAIN BOOM TRAVEL	-30° to 75°	-30° to 75°	-30° to 75°	-30° to 75°	-15° to 80°
EXTENSION TRAVEL	120"	120"	120"	96"	120"

Dur-A-Lift Inc. reserves the right to improve models and change specifications without notice or obligation. Dur-A-Lift equipment meets or exceeds all applicable ANSI Standards as of the date of manufacture.

*Maximum height achievable with addition of the optional 22" basket elevator.
**Telescopic aerial lift

- WORKING HEIGHT UP TO 59'; SIDE REACH TO 31'6"
- MATERIAL HANDLING OR DOUBLE-PERSON
- 180-DEGREE BASKET ROTATOR
- BASKET ELEVATOR OPTION
- TOP-MOUNTED JIB LIFTS UP TO 1000#
- INSULATED (DPM2); NON-INSULATED (DPM2S)



MANY WAYS TO CUSTOMIZE!

DUR-A-LIFT®
WE SPEAK BUCKET TRUCK

DPM2 SERIES

Models: DPM2-52, DPM2-47, DPM2-40, DPM2-36, DPM2-32

STANDARD

Proportional controls; lower override controls; engine start/stop from basket; basket access from ground; compensated upper boom; hydraulic basket leveling; rotating basket; continuous rotation; joystick and lockout controls; 180° basket rotator

BASKET CONFIGURATIONS

MH BASKET: Single-person, material handling; top-mounted jib and winch lifts up to 1000#; upper and lower winch control; 400# basket capacity; 24" X 30" fiberglass or aluminum basket

DP BASKET: Double-person, personnel; 600# basket capacity; 24" X 42" fiberglass or aluminum basket

DU BASKET: Dual configuration; double-person, personnel or single-person, material handling; top-mounted jib and winch lifts up to 1000#; 550# basket capacity when not using winch; 400# basket capacity when using winch; 24" X 42" fiberglass or aluminum basket

OPTIONAL

22" basket elevator; high electrical resistant controls; outriggers; basket liner for fiberglass baskets; fiberglass main and articulating booms; tool circuits; D.C. backup system; non-insulated version available (DPM2S); 110 v outlet at basket (DPM2S only)



MH BASKET CONFIGURATION
SINGLE-PERSON, MATERIAL HANDLING



DU BASKET CONFIGURATION
DUAL CONFIGURATION: MATERIAL HANDLING OR DOUBLE-PERSON

INSULATED OR NON-INSULATED

Available in insulated (Cat. C or D) or non-insulated formats. Full pressure controls.

Insulated: DPM2

Non-insulated: DPM2S

REACH DIAGRAM DPM2-32

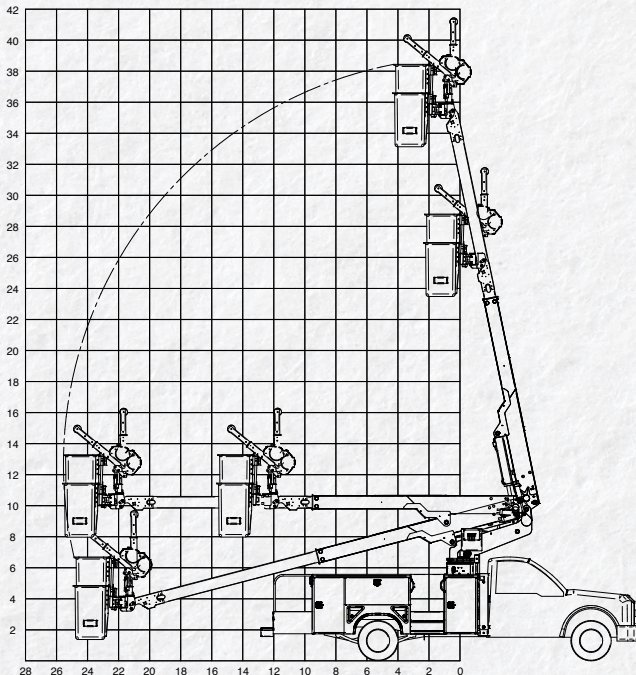

CHASSIS REQUIREMENT, MIN.: 19,000 GVWR
CHASSIS CAB TO AXLE REQUIREMENT, MIN.: 84"

REACH DIAGRAMS DPM2-36, DPM2-40

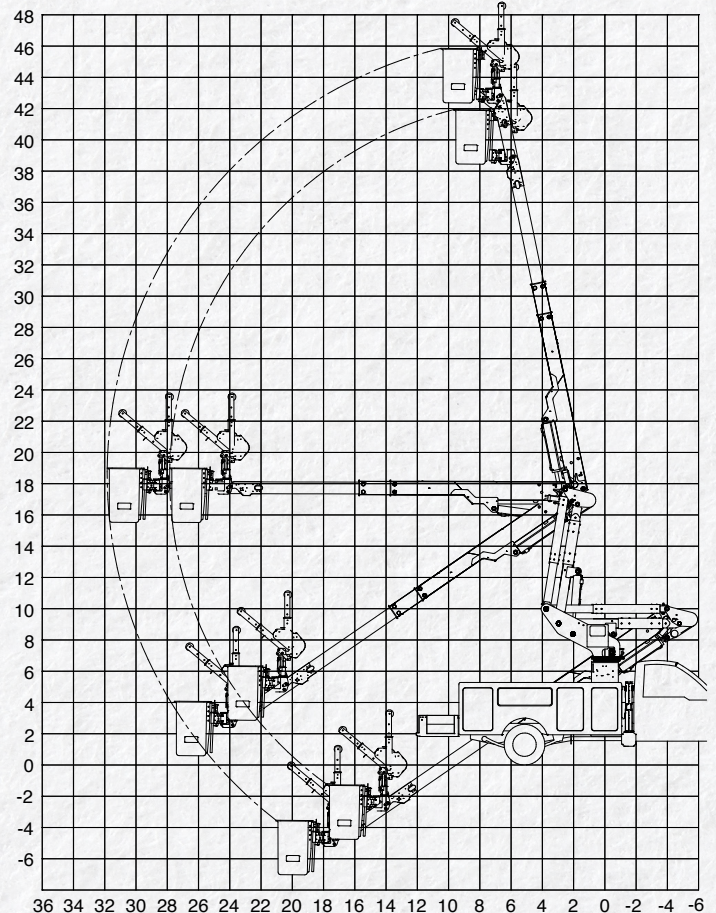

CHASSIS REQUIREMENT, MIN.: 19,500 GVWR
CHASSIS CAB TO AXLE REQUIREMENT, MIN.: 60" (DPM2-36); 84" (DPM2-40)



DP BASKET CONFIGURATION
DOUBLE-PERSON, PERSONNEL



BASKET ACCESS

The DPM2's negative boom angle not only allows you to access the basket from ground level but also allows for convenient access to the storage compartments without leaving the basket.



DPM2 MODELS

Dur-A-Lift's DPM2 series aerial lift features five models that have max working heights that range from 39 to 59 feet*. All models can be equipped with an MH, DU, or DP basket in fiberglass or aluminum.

TELESCOPIC



DPM2-32DU REACH UP TO 39'

TELESCOPIC ARTICULATED



DPM2-36MH REACH UP TO 43'



DPM2-40MH REACH UP TO 47'



DPM2-47DU REACH UP TO 54'



DPM2-52DU REACH UP TO 59'

*Max working height achievable with use of optional basket elevator

REACH DIAGRAMS DPM2-47, DPM2-52

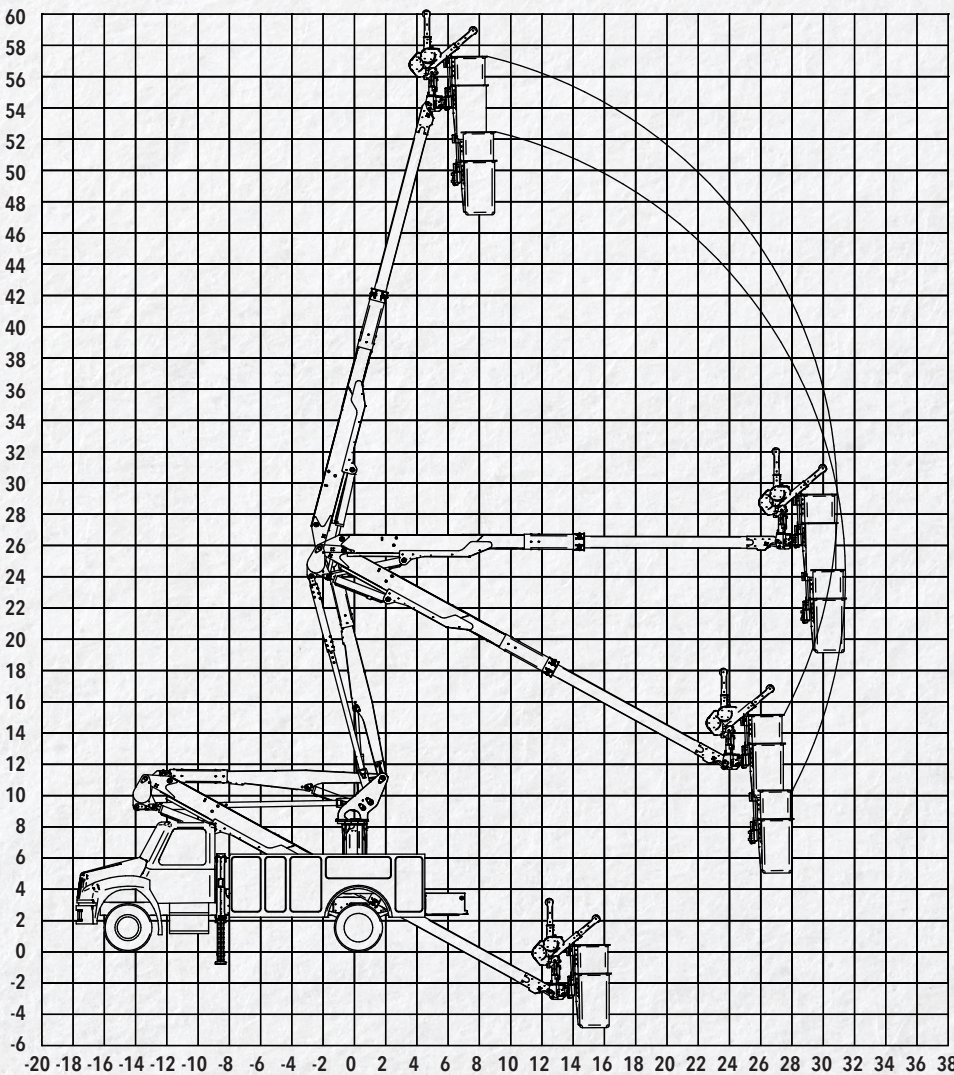

CHASSIS REQUIREMENT, MIN.: 19,500 GVWR (DPM2-47); 22,000 GVWR (DPM2-52)
CHASSIS CAB TO AXLE REQUIREMENT, MIN.: 84" (DPM2-47); 94" (DPM2-52)

DUR-A-LIFT
WE SPEAK BUCKET TRUCK

DPM2 SERIES

Models: DPM2-52, DPM2-47, DPM2-40, DPM2-36, DPM2-32

DUR-A-LIFT
WE SPEAK BUCKET TRUCK



BASKET ELEVATOR

The hydraulically activated basket elevator (optional) allows the operator to raise the basket without repositioning the booms or the jib.



TOP-MOUNTED JIB & WINCH

The top-mounted jib and winch (DU, MH baskets) allows the operator to rotate the jib to work on either side of the rotating basket.



**BUILT FOR YOU;
BUILT TO LAST.**
Trust Dur-A-Lift for all of your bucket truck needs.
www.dur-a-lift.com



Many great options for those in the electric utility and sign/lighting industries!



DPM2 SERIES BUILDS

Build the perfect bucket truck for you and your needs. Ask about available chassis, body, basket, tailshelf, and accessory options for the DPM2 series bucket truck.



READ MORE